

DESCRIPTIONS

AD6392 is a 4-CH BTL driver suitable for driving motors and actuators in CD-P/VCD-P systems. Each channel drivers except the spindle driver have an internal primary filter and they can be directly connected to the servo's PWM output without any attached external components.

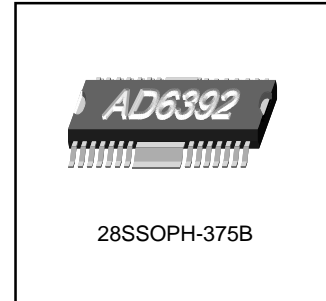

FEATURES

- 3-CH BTL driver compatible with PWM input (PWM input is filtered by an internal primary filter, so there is no need to attach external components)
- 1-CH BTL spindle driver with analog input
- Built-in TSD (thermal shut down) circuit.
- Built-in mute circuit.
- Operating supply voltage (4.5V~13.2V).

ORDER INFORMATION

Device	Package	Operating Temp
AD6392	28SSOPH-375A	-35°C ~ +85°C
AD6392	28SSOPH-375B	-35°C ~ +85°C

BLOCK DIAGRAM

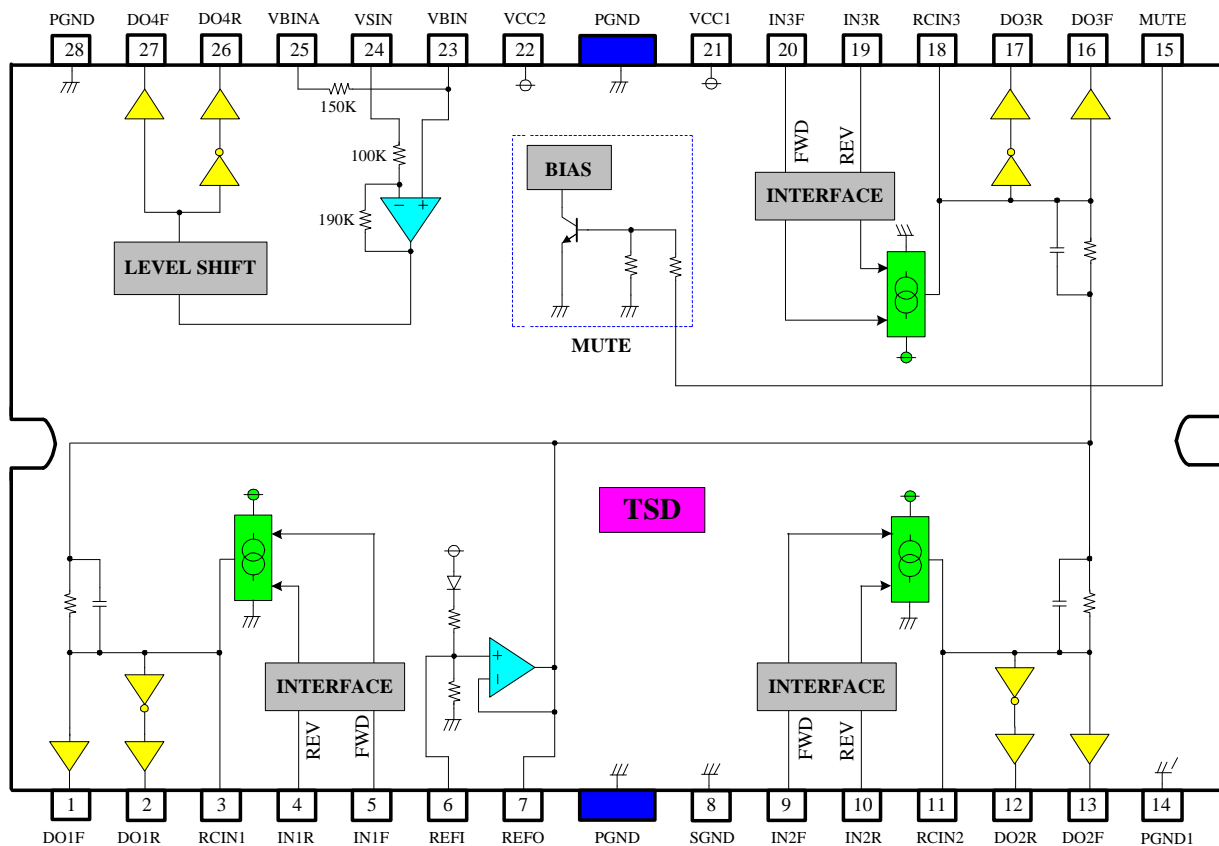

PIN CONNECTIONS

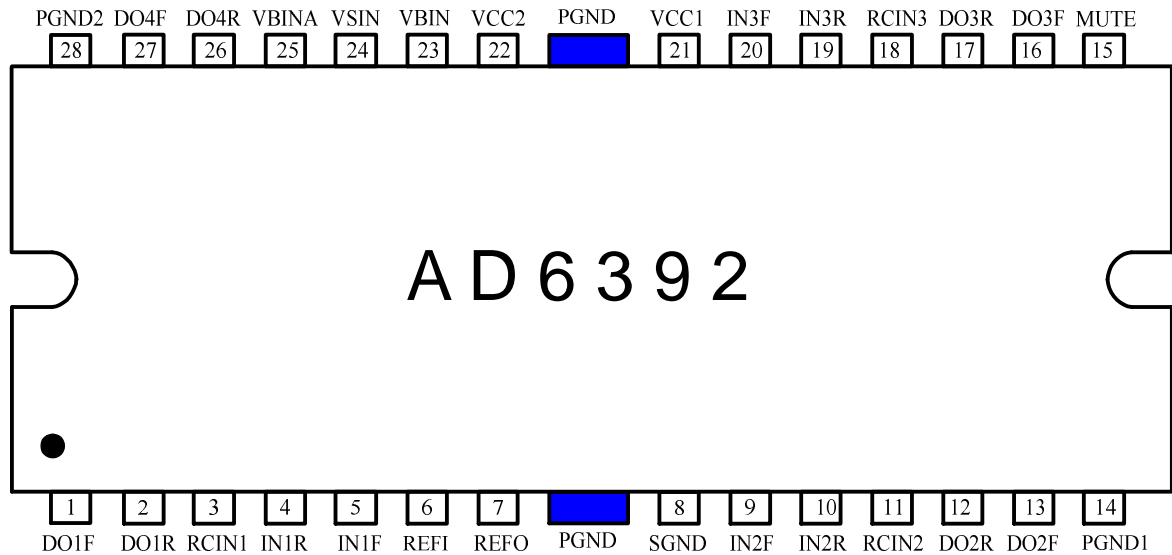

PIN DESCRIPTIONS

NO	SYMBOL	I/O	DESCRIPTION	NO	SYMBOL	I/O	DESCRIPTION
1	DO1F	O	CH1 forward output	15	MUTE	I	Mute
2	DO1R	O	CH1 reverse output	16	DO3F	O	CH3 forward output
3	RCIN1	I	CH1 external capacitor / resistor	17	DO3R	O	CH3 reverse output
4	IN1R	I	CH1 reverse input	18	RCIN3	I	CH3 external capacitor / resistor
5	IN1F	I	CH1 forward input	19	IN3R	I	CH3 reverse input
6	REFI	I	Reference input	20	IN3F	I	CH3 forward input
7	REFO	O	Reference output	21	VCC1	-	Power supply voltage 1
8	SGND	-	Signal ground	22	VCC2	-	Power supply voltage 2
9	IN2F	I	CH2 forward input	23	VBIN	I	CH4 bias input
10	IN2R	I	CH2 reverse input	24	VSIN	I	CH4 input
11	RCIN2	I	CH2 external capacitor / resistor	25	VBINA	I	CH4 bias input (with internal resistor)
12	DO2R	O	CH2 reverse output	26	DO4R	O	CH4 reverse output
13	DO2F	O	CH2 forward output	27	DO4F	O	CH4 forward output
14	PGND1	-	Power ground 1	28	PGND2	-	Power ground 2

ABSOLUTE MAXIMUM RATINGS

CHARACTERISTICS	SYMBOL	VALUE	UNIT
Maximum supply voltage	VCCmax	18	V
Power dissipation 1 (375A_Type)	Pd 1	1.7 *	W
Power dissipation 2 (375B_Type)	Pd 2	2.3 *	W
Operating temperature	Topr	-35 ~ +85	°C
Storage temperature	Tstg	-55 ~ 150	°C

Note>

- When mounted on 100mm X 100mm X 1mm PCB (Phenolic resin material).
- Power dissipation reduces 13.6 mW/°C(375A_Type), 18.4 mW/°C(375B_Type), for using above Ta=25°C
- Do not exceed Pd and SOA.

POWER DISSIPATION CURVE

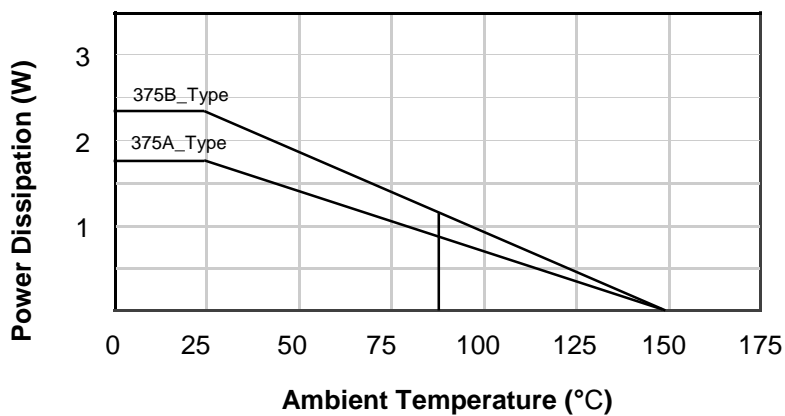

RECOMMENDED OPERATING CONDITIONS

CHARACTERISTICS	SYMBOL	VALUE	UNIT
Operating Supply Voltage	VCC1,2	4.5~ 13.2	V

ELECTRICAL CHARACTERISTICS

(VCC1=VCC2=8V, f = 1kHz, RL = 8ohm, Ta = 25°C unless otherwise specified.)

CHARACTERISTICS	SYMBOL	CONDITIONS	MIN	TYP	MAX	UNIT
Quiescent Circuit Current	Icc	No Load	-	6.5	-	mA
PREFO Pin Voltage	Vbias	-	3.40	3.70	4.00	V
PREFO Pin Voltage Variance	ΔVbias	1mA Source, sink	-30	-	30	mV
All Mute On Voltage	Vamon	Pin6=variation	-	-	0.5	V
All Mute Off Voltage	Vamoff	Pin6=variation	2.0	-	-	V
Mute On Voltage	Vmon	Pin15=variation	-	-	0.5	V
Mute Off Voltage	Vmoff	Pin15=variation	2.0	-	-	V
Mute on current	Imute	-	-	-	3	mA
[DRIVE PART (CH1,CH2,CH3)]						
Input High Level Voltage	Vih	-	2.4	-	-	V
Input Low Level Voltage	Vil	-	-	-	0.5	V
Input High Level Current	Iih	Vin = 5V	50	100	150	uA
Input Low Level Current	Iil	Vin = 5V	-	0	-	uA
Output Offset Voltage 1,2,3	Voo	-	-40	-	+40	mV
Output High Level Voltage	Vohd	FWD = 5V, REV = 0V	5.2	5.8	-	V
Output Low Level Voltage	Vold	FWD = 0V, REV = 5V	-	1.1	1.6	V
Constant Current	Iconst	-	14	22	30	uA
Internal integral Capacitance	C	-	-	24	-	pF
Current Pulse rise time 1	Δ tr	At startup	-	0.08	1	us
Current Pulse fall time 2	Δ tf	At shutdown	-	0.55	1	us
Current Pulse time differential	Δ tr-f	-	-160	-	160	us
Drive Linearity	Δ LIN	Vin = Vref±0.5, 1, 1.5V*1	90	100	110	%
Ripple Rejection	RR	Vin = 100mVrms, 100Hz	-	70	-	dB

*1. If Vo = Vo1 when Vin = Vref±0.5V, Vo = Vo2 when Vin = Vref±1.0V, and Vo = V3 when Vin = Vref±1.5V, then $\Delta Lin = (Vo3/Vo2)(Vo2/Vo1) \times 100\%$

ELECTRICAL CHARACTERISTICS

(VCC1=VCC2=8V, f = 1kHz, RL = 8ohm, Ta = 25°C unless otherwise specified.)

[DRIVE PART (CH4)]						
Input Bias Current	Ib	-	-	-	300	nA
Common mode input range	Vicm	-	1.6	-	6.4	V
Maximum Output Voltage High	Vohs	-	5.2	5.8	-	V
Maximum Output Voltage Low	Vols	-	-	1.1	1.6	V
Voltage Gain	Gvc	-	8	10.5	13	dB
Output offset voltage 4	Voos	-	-60	0	60	mV
Slew Rate	SR	-	-	2	-	V/us
Ripple Rejection Ratio	RRs	Vin = 100mVrms, 100Hz	-	70	-	dB

APPLICATION SUMMARY

- Mute function through power reference or signal reference pins

Muting all channel drivers can be obtained through power reference or signal reference pins. Fig.1 shows the simplified schematic diagram for power/signal reference mute.

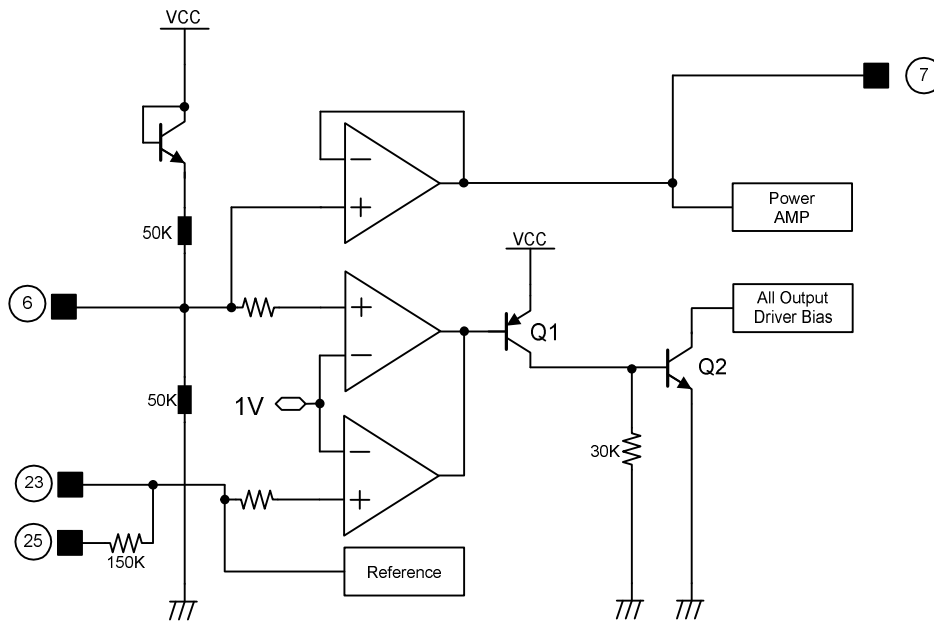

Fig. 1 Power reference, Signal reference & all mute function

Pin6, Pin23, Pin25	Mute
Above 1.0V	off
Below 1.0V	on

As it can be seen in Fig. 1, pin6, pin23 and pin25 are connected to the positive input terminals of comparators, and the internal 1.0V reference is connected to the negative input terminals. Thus, if the voltage applied to each pins falls below 1.0V, Q1 and Q2 become on and hence the bias currents for all channel drivers become to be shut down. Thus all mute function can be carried out.

APPLICATION SUMMARY (Continued)

- Mute function through MUTE pin

Mute function is also performed at MUTE pin (pin15). The logic is as follows:

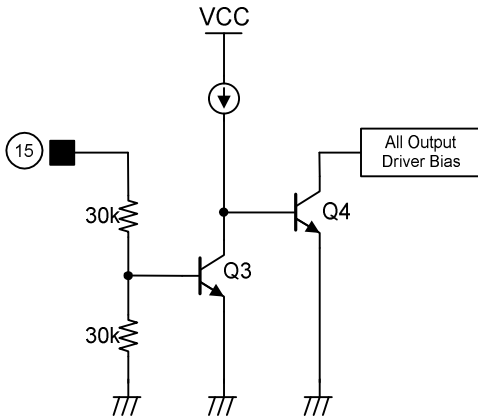

Pin15	Mute
High	off
Low	on

As it can be seen in Fig. 2, If the voltage of the pin15 become low (below 0.5V) or open, Q3 becomes off and Q4 on, and hence the bias currents for all channel drivers are shut down and muted. If the voltage of the pin15 become high (above 2.0V), the channel drivers operate normally.

Fig. 2 Mute function

- Thermal shutdown (TSD)

The AD6392 has a thermal protection against the abnormal high temperature operation to protect the chip.

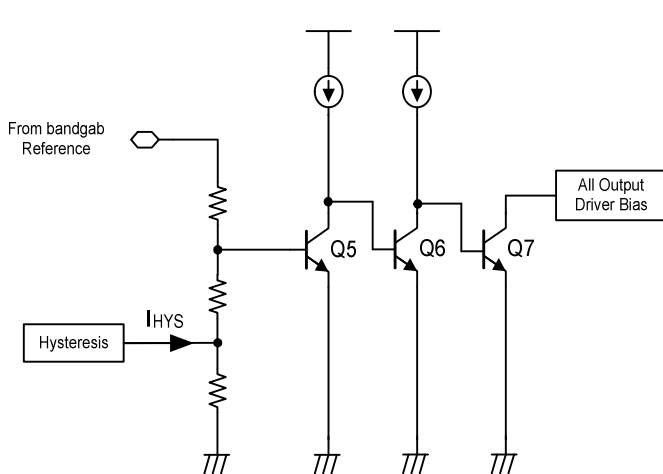

Temperature	mute
Above 175 °C	on
Falls below 150 °C	off
Hysteresis	25 °C

Fig. 3 Thermal shut down

Q5 is biased through the resistor string from the internal bandgap reference voltage so that it remains in off state at the ranges of the normal operating temperatures. If the junction temperature rises above 175°C, Q5 turns into on state and hence Q7 turns on, and all channel drivers are muted as the bias currents are shut down. When the junction temperature falls below 150 °C, Q5 and Q7 are turned off and the drivers operate normally. The hysteresis temperature is, thus, 25 °C

APPLICATION SUMMARY (Continued)

- CH1, CH2 and CH3 Drive Parts (Focus, Tracking , Sled Drivers)

CH1, CH2 and CH3 drive parts are composed of internal filter, V-I converter and output power amplifiers.

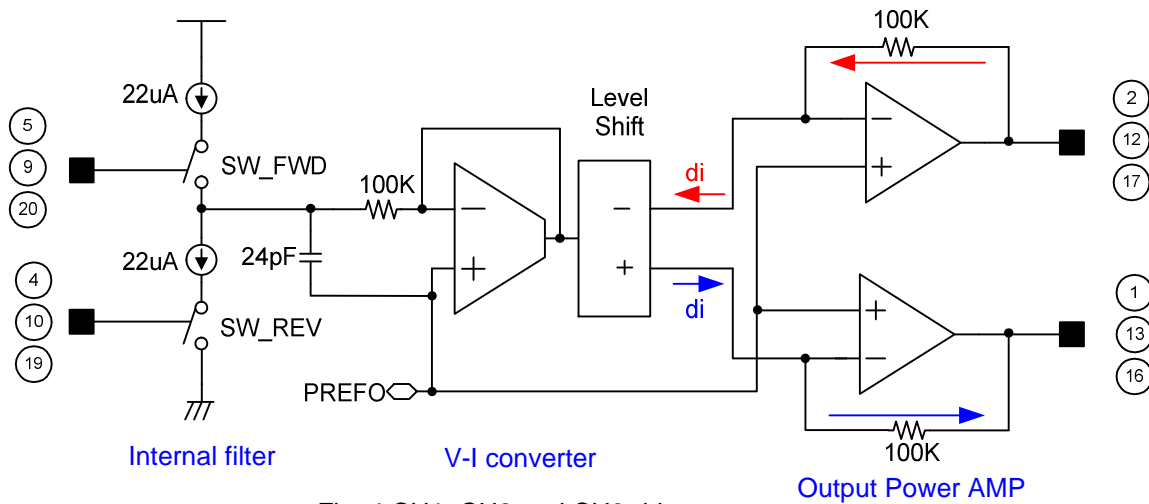

Fig. 4 CH1, CH2 and CH3 drive parts

- Internal primary filter

Internal primary filter is composed of sourcing/sinking current source of 22uA and forward/reverse controlled switches. It converts “FWD/REV” digital signals to analog signal as shown in Fig. 5.

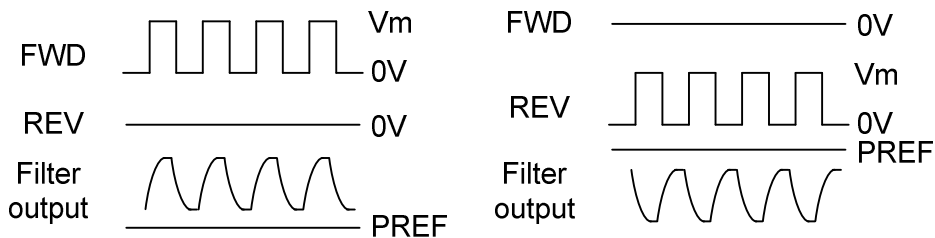

Fig. 5 Output signal waveforms of the primary filter

- V-I converter

V-I converter converts filtered analog voltage signal to positive or negative steering current signals and delivers them to output power amplifiers.

- Output power amplifier

Output power amplifiers with a unity feedback configuration re-convert the current outputs of V-I converters to differential output voltage to drive motors in BTL mode.

APPLICATION SUMMARY (Continued)

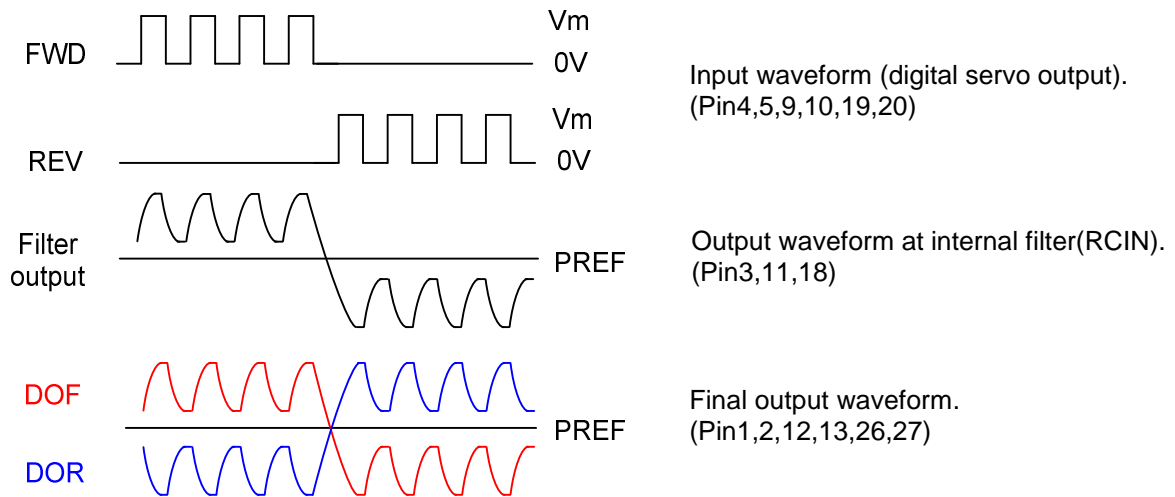

Fig. 6 Operation waveforms of CH1, CH2 and CH3 drive parts

- Operation principle

If FWD is high and REV is low, then SW_FWD and SW_REV become on and off, respectively.

This causes the internal capacitor to be charged with sourcing current of 22 uA and consequently the voltage of the filter output (RCIN) increases with the internal time constant of 2.4usec (time constant = R*C=24 pF * 100 Kohm =2.4usec). Then the output current of V-I converter is given by

$$di = \left| \frac{VRCIN}{100K} \right|$$

The output voltages of power amplifiers are, then, given as:

$$DOF = Pref + RCIN$$

$$DOR = Pref - RCIN$$

APPLICATION SUMMARY (Continued)

- CH4 spindle drive part

CH4 drive part is composed V-I converter and output power amplifiers.

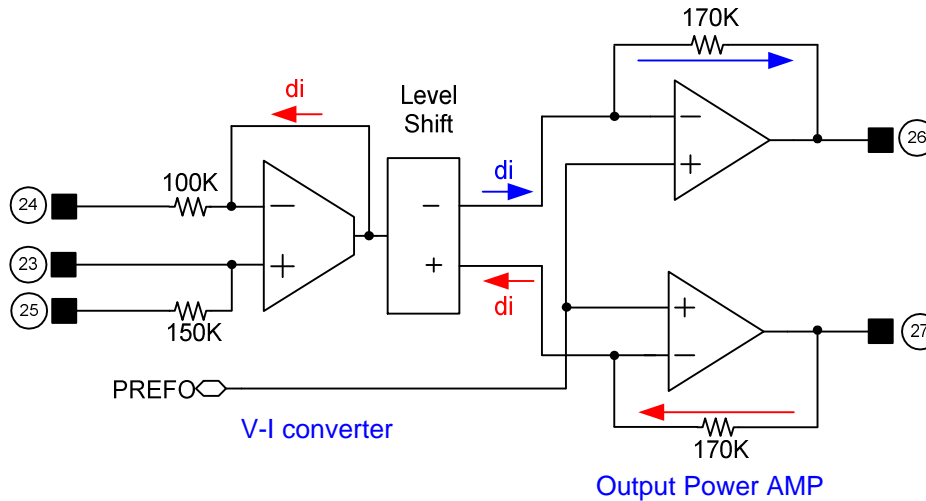

Fig. 7 CH4 spindle drive part

- The V-I converter converts the input voltage applied to pin24 into a incremental output current given by

$$di = \left| \frac{V_{in} - V_{ref}}{100K} \right| = \left| \frac{\Delta V_{in}}{100K} \right| \quad \Delta V_{in} = V_{in} - V_{ref} \quad \begin{array}{l} * V_{in} = \text{input voltage of pin24} \\ * V_{ref} = \text{reference voltage (pin23 or pin25)} \end{array}$$

- These sourcing and sinking output current from V-I converter are delivered to output power amplifiers, where they are appeared as differential output voltages given as:

$$\begin{aligned} DOF &= Pref + di * 170K \\ DOR &= Pref - di * 170K \end{aligned}$$

- The differential voltage gain is, then, calculated as follows:

$$\begin{aligned} \Delta V_{out} &= DOF - DOR = 2 * di * 170K \\ A_{vf} &= 20 \log \left| \frac{\Delta V_{out}}{\Delta V_{in}} \right| = 20 \log \left| \frac{2 * 170K}{100K} \right| = 10.6dB \end{aligned}$$

TEST CIRCUIT

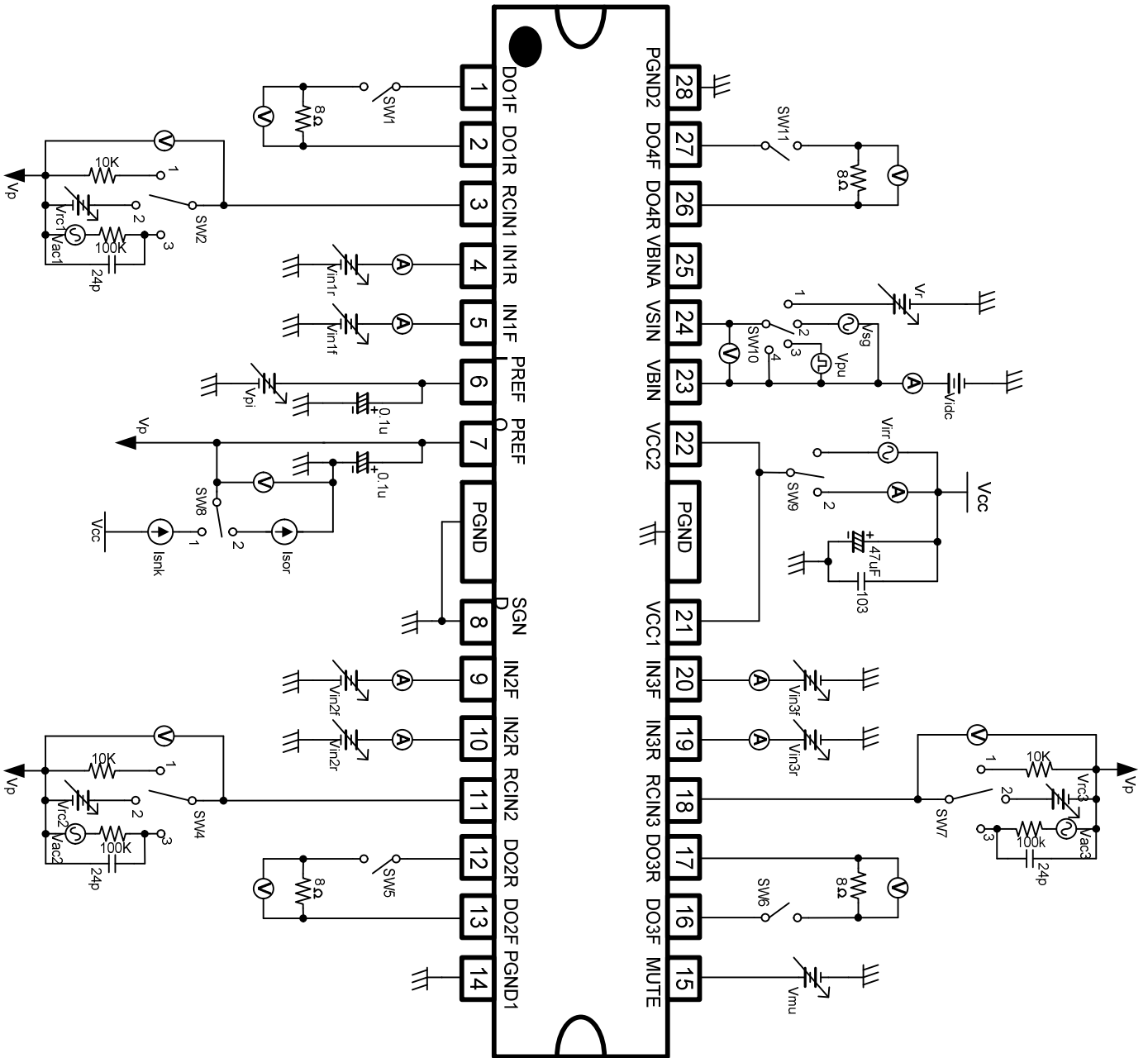

TYPICAL APPLICATION CIRCUIT

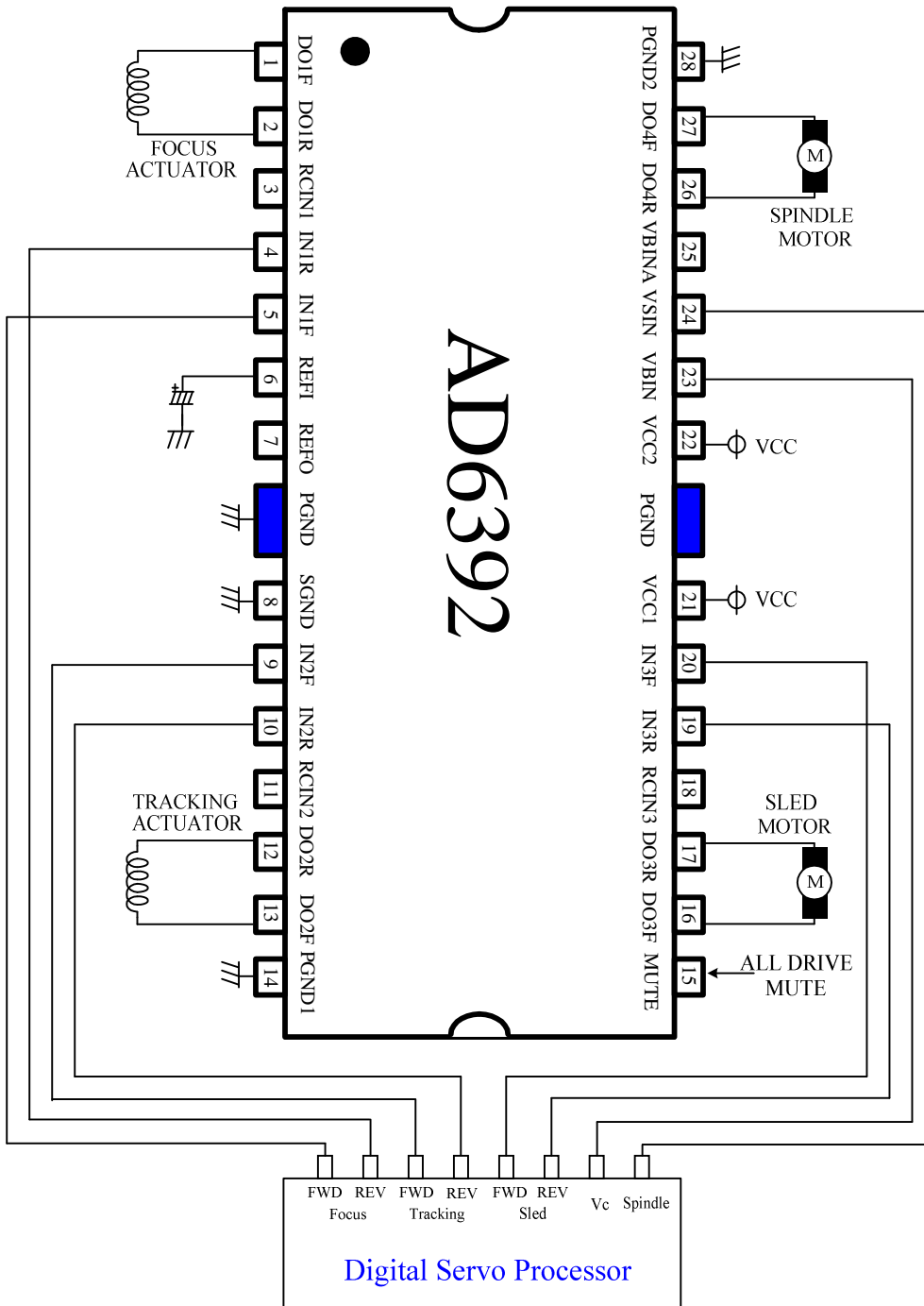

INTERNAL CIRCUIT

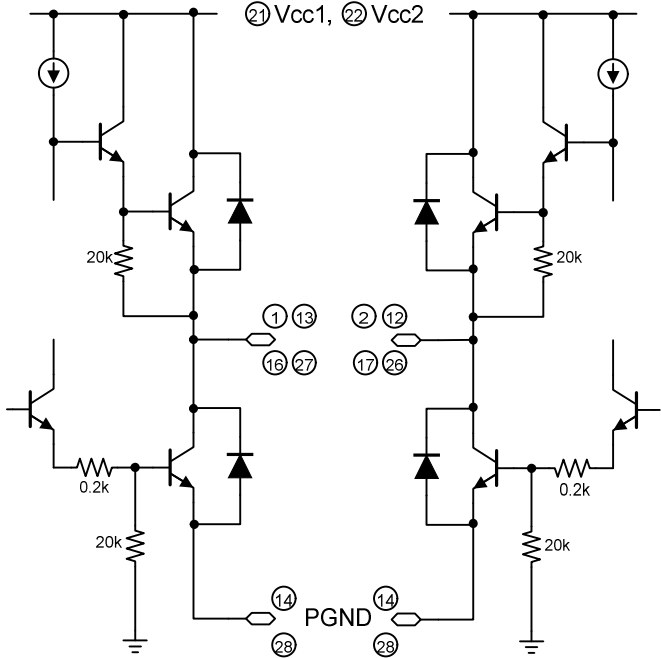
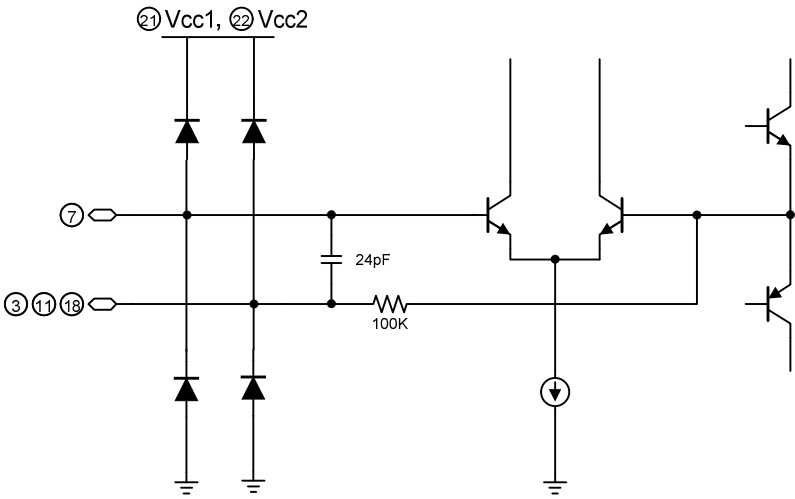
Pin no	Pin name	Internal circuit
1,2, 12,13, 16,17, 26,27	DO1F, DO1R, DO2R, DO2F, DO3F, DO3R, DO4R, DO4F	
3, 11, 18	RCIN1, RCIN2, RCIN3	

INTERNAL CIRCUIT (Continued)

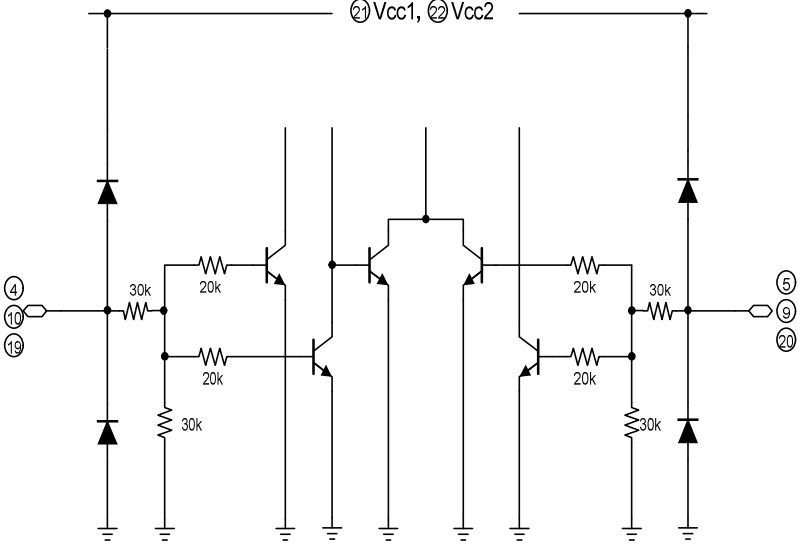
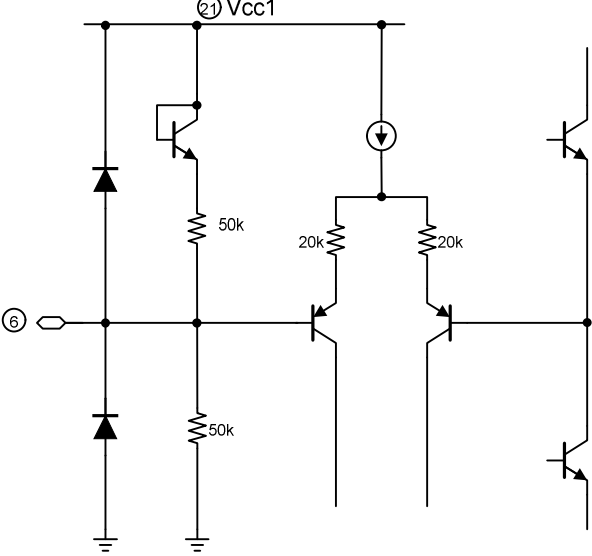
Pin no	Pin name	Internal circuit
4,5, 9,10, 19,20	IN1R, IN1F, IN2F, IN2R, IN3R, IN3F	
6	PREFI	

INTERNAL CIRCUIT (Continued)

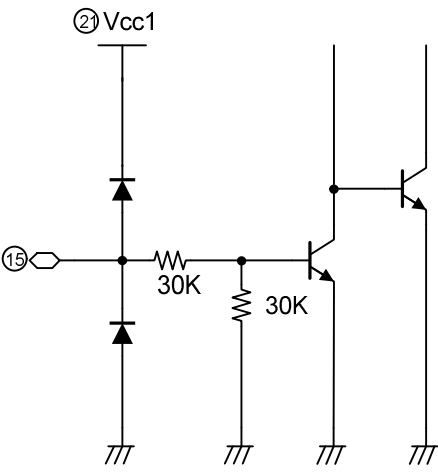
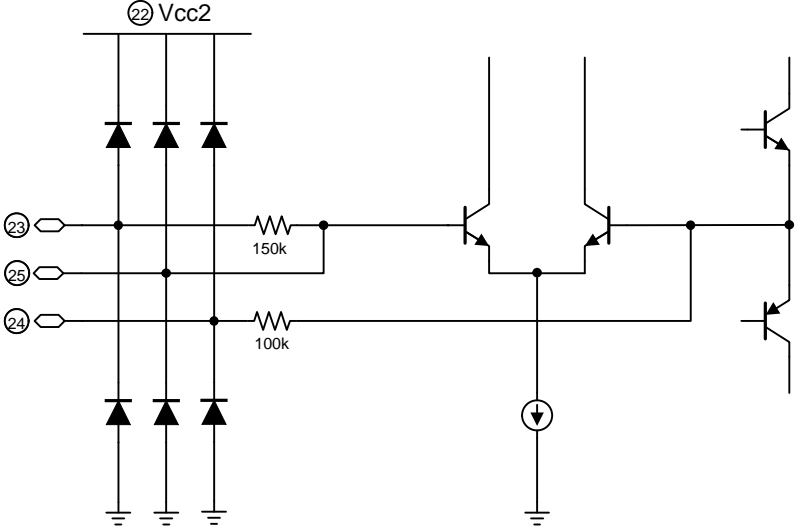
Pin no	Pin name	Internal circuit
15	MUTE	
23, 24, 25	VBIN, VSIN, VBINA	

ELECTRICAL CHARACTERISTICS CURVES

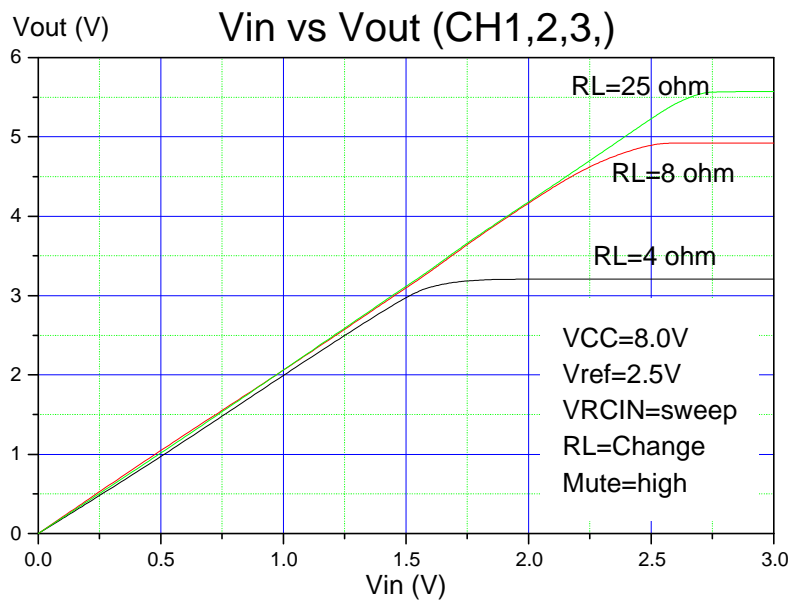
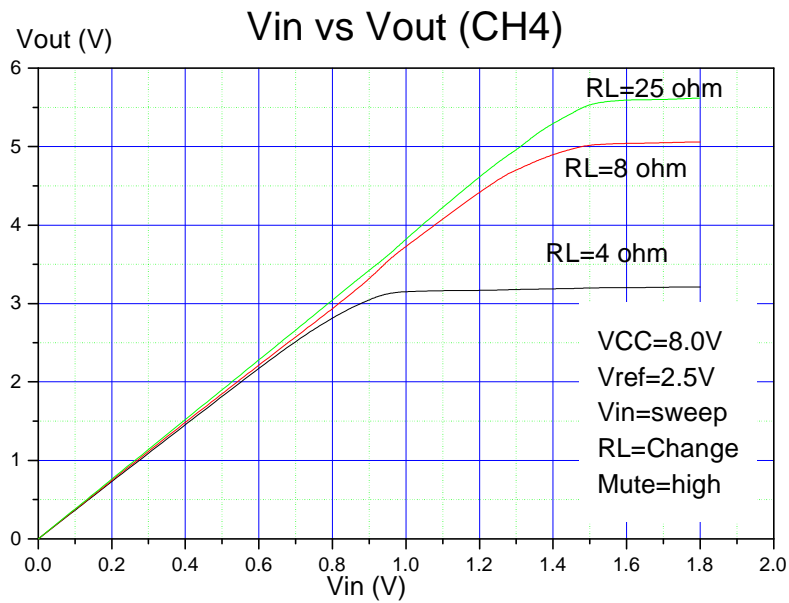

ELECTRICAL CHARACTERISTICS CURVES (Continued)

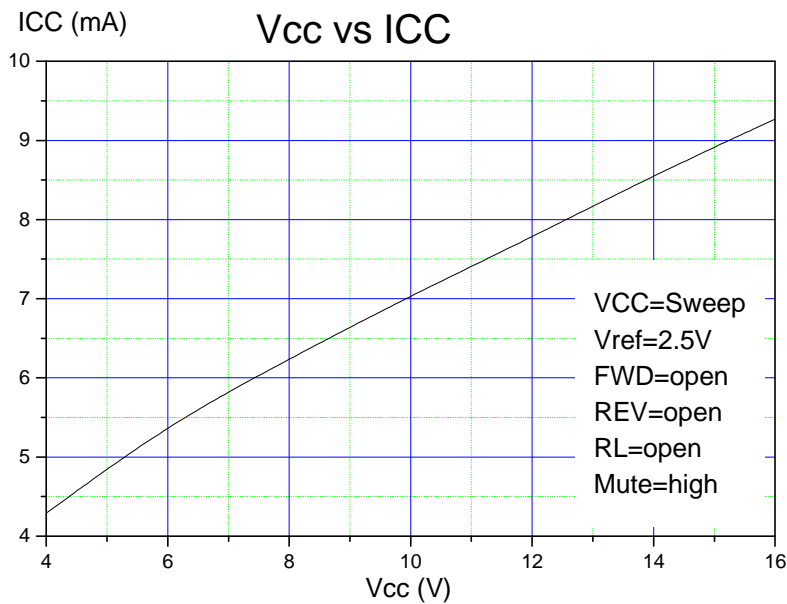
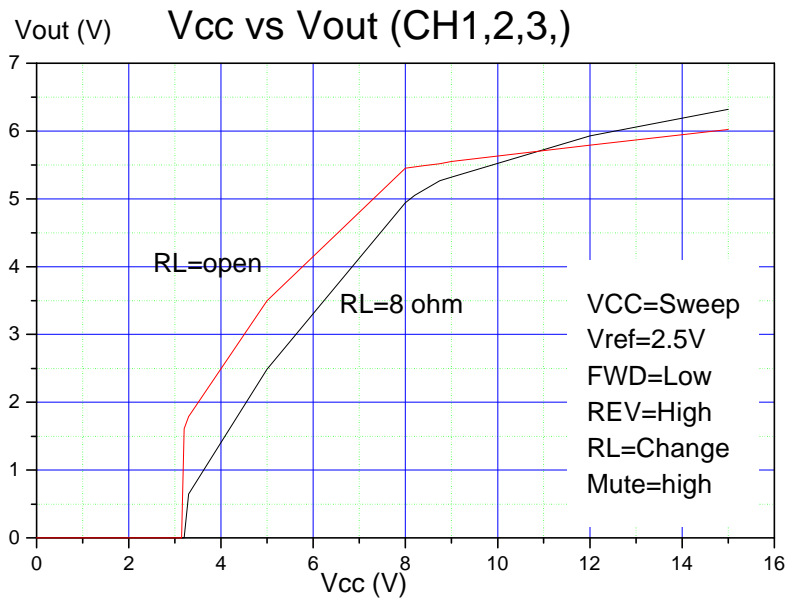

ELECTRICAL CHARACTERISTICS CURVES (Continued)

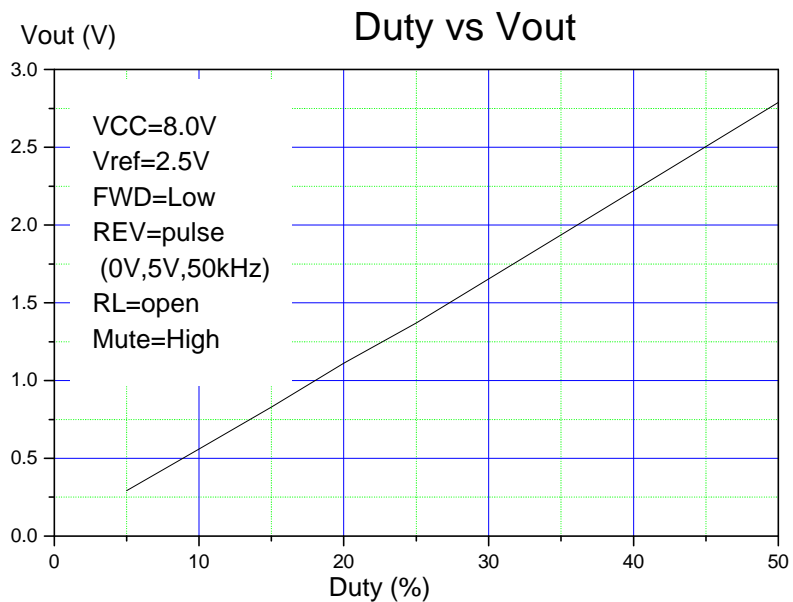
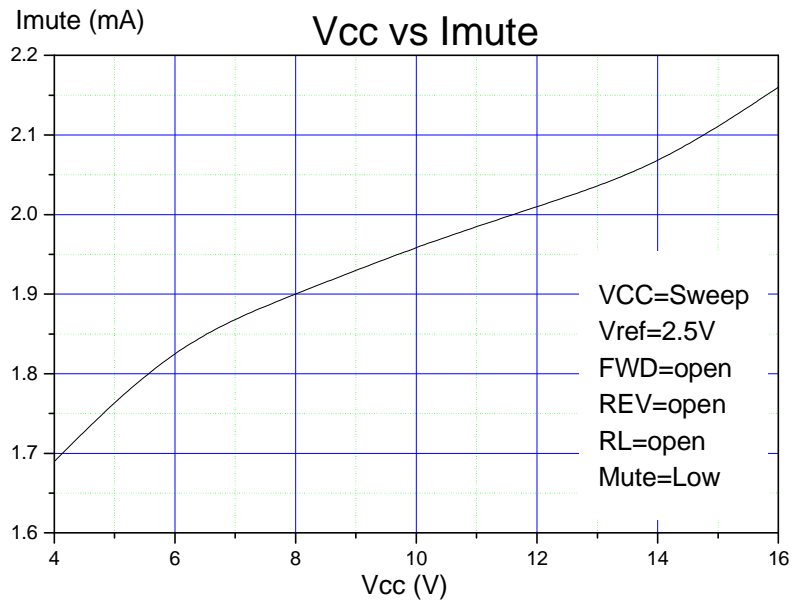

ELECTRICAL CHARACTERISTICS CURVES (Continued)

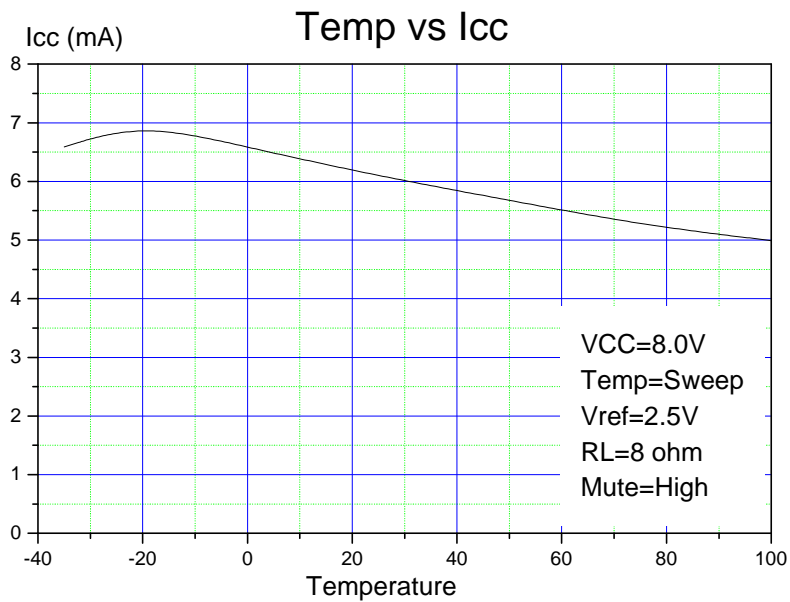
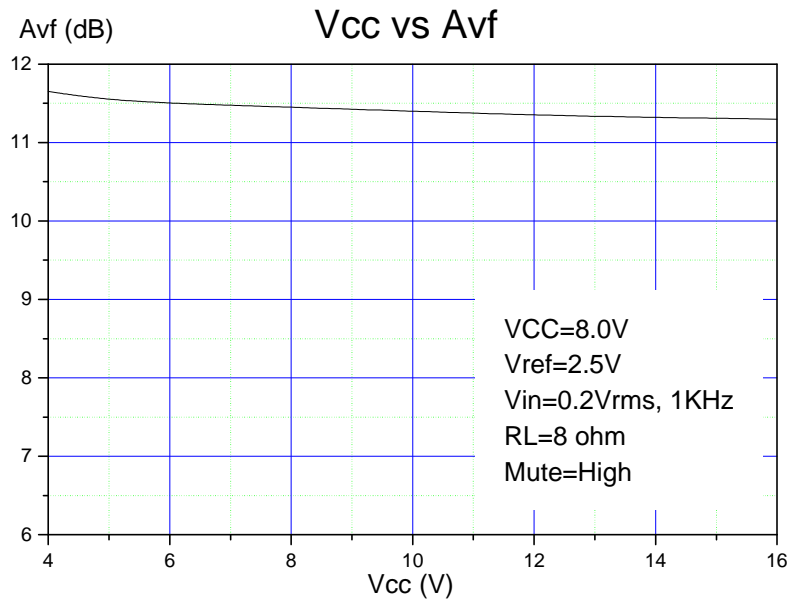

ELECTRICAL CHARACTERISTICS CURVES (Continued)

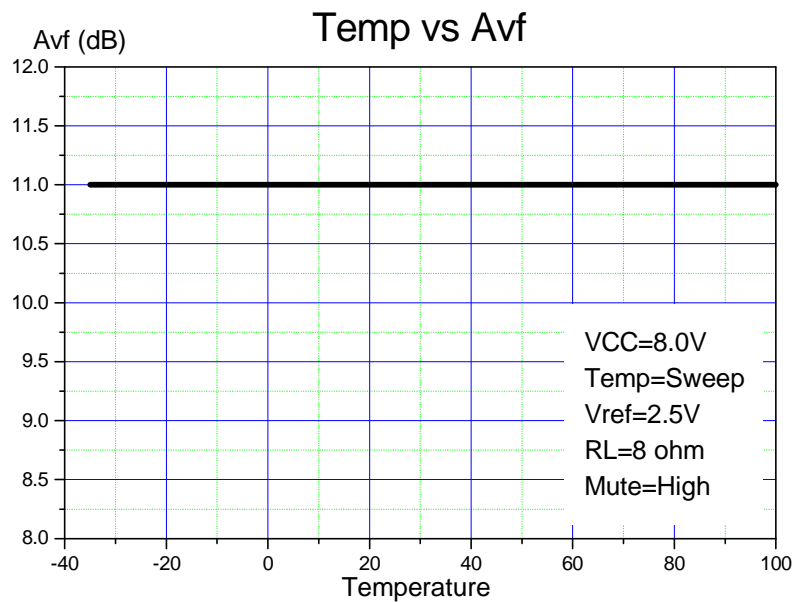
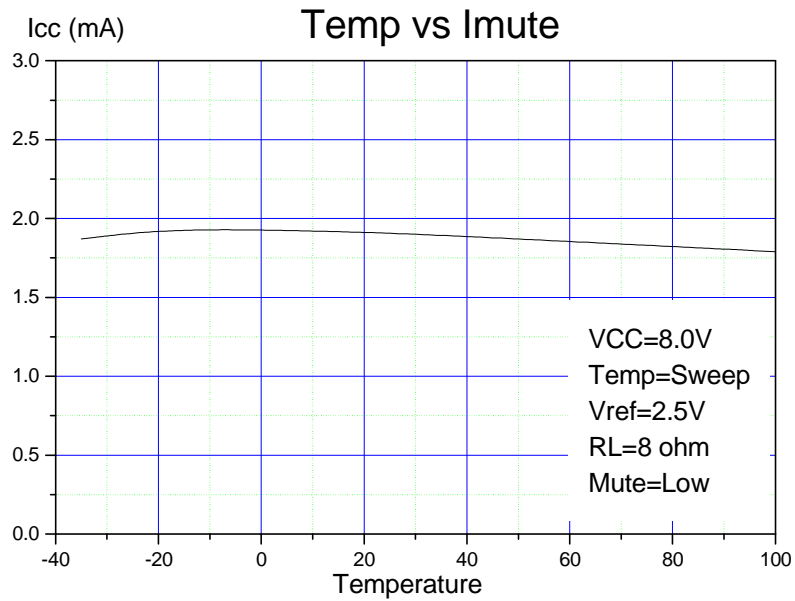

[28SSOPH_375A_Type]

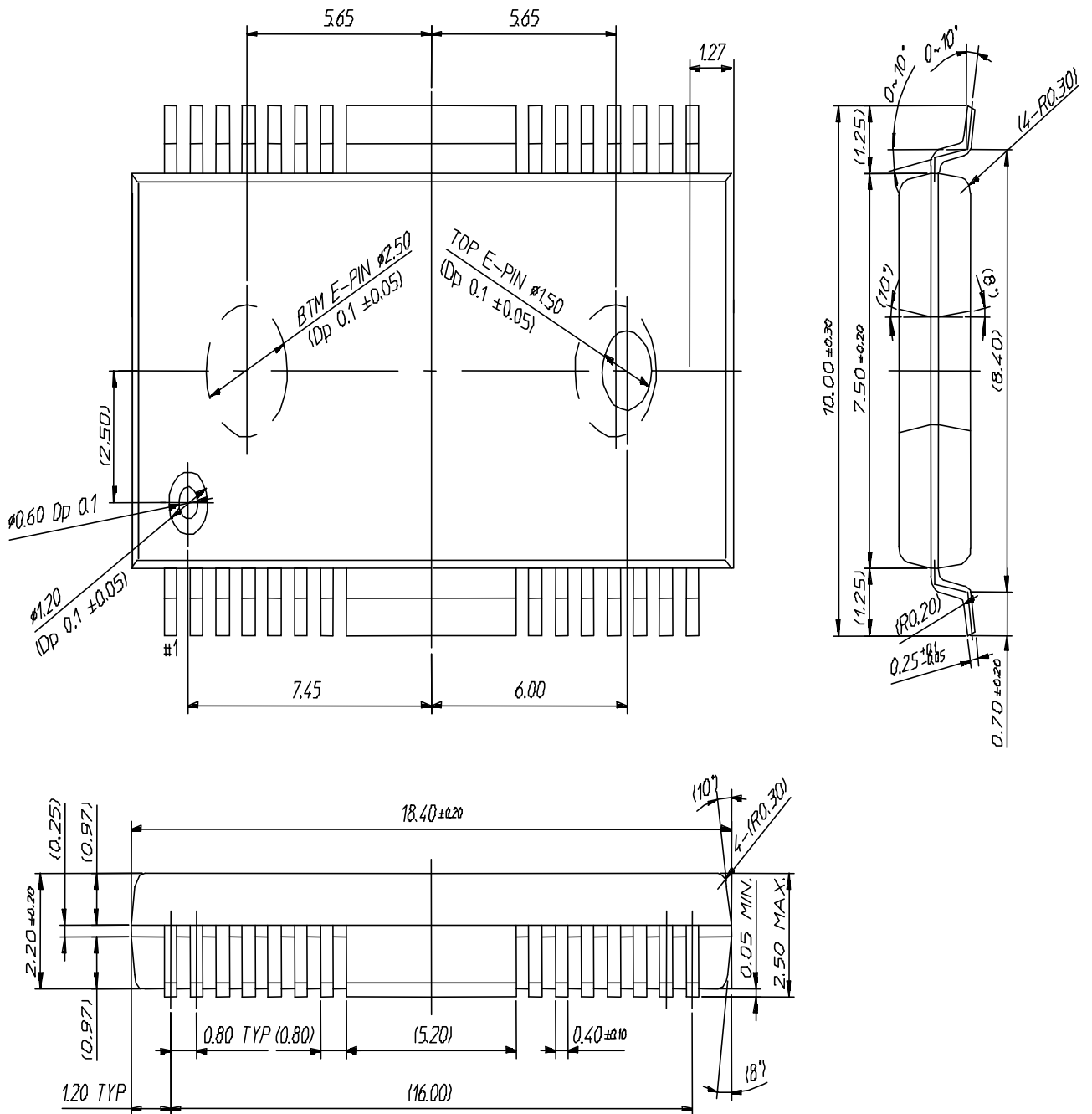

PACKAGE DIMENSION

[28SSOPH_375B_Type]

